

# 9000A SERIES OVERHEAD HOLDERS & STOPS

- SURFACE MOUNT
- HEAVY DUTY
- ADJUSTABLE
- 9010A HOLD-OPEN
- 9020A STOP
- 9030A FRICTION

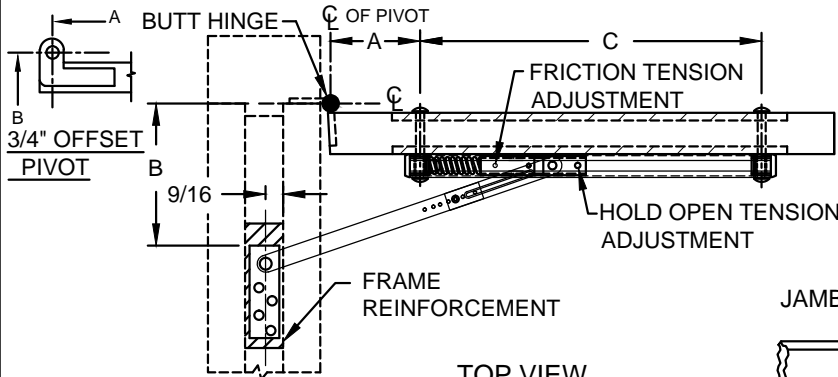

A =  $\ell$  OF PIVOT POINT TO  $\ell$  OF FIRST CHANNEL SEX BOLT  
 B =  $\ell$  OF PIVOT POINT TO START OF JAMB BRACKET CUT-OUT  
 C =  $\ell$  OF FIRST SEX BOLT TO  $\ell$  OF SECOND SEX BOLT OF CHANNEL.

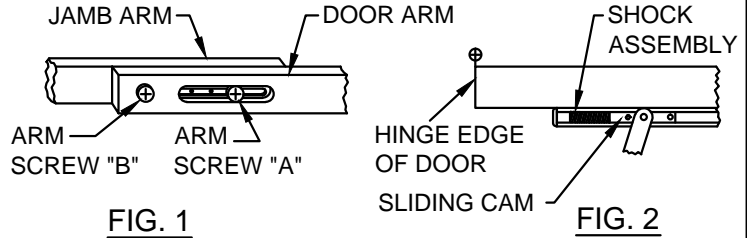
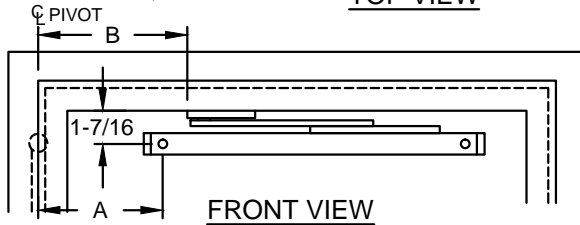

- TO CHANGE HOLD OPEN OR STOP DEGREE**
1. LOOSEN "ARM SCREW A" IN SLOTTED SECTION. SEE FIG. 1. DO NOT REMOVE.
  2. REMOVE "ARM SCREW B" ONLY. SEE FIG. 1.
  3. OPEN DOOR TO DESIRED DEGREE.
  4. POSITION "SLIDING CAM" AGAINST SHOCK ASSEMBLY. SEE FIG. 2.
  5. INSTALL "ARM SCREW B" IN ARM AND SECURE.
  6. TIGHTEN "ARM SCREW A" SECURELY.

**CAUTION:**  
 ARM SCREW "B" MUST BE INSTALLED AND BOTH SCREWS "A" AND "B" SECURED OR UNIT WILL FAIL TO HOLD POSITION

SCREW DETAIL			
	QTY	WOOD	METAL
JAMB	4	● #14 x 1-1/2" FLAT HEAD WOOD SCREW	● 1/4-20 x 3/4" FLAT HEAD MACHINE SCREW
DOOR	2	● 5/16-18 x 2" TRUSS HEAD MACHINE SCREW ● 1/2 DIA. SEX BOLT	

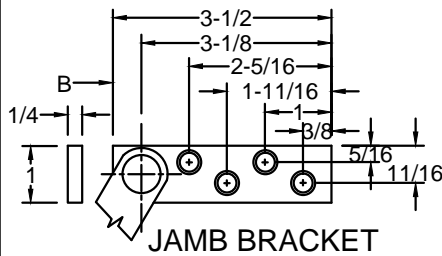
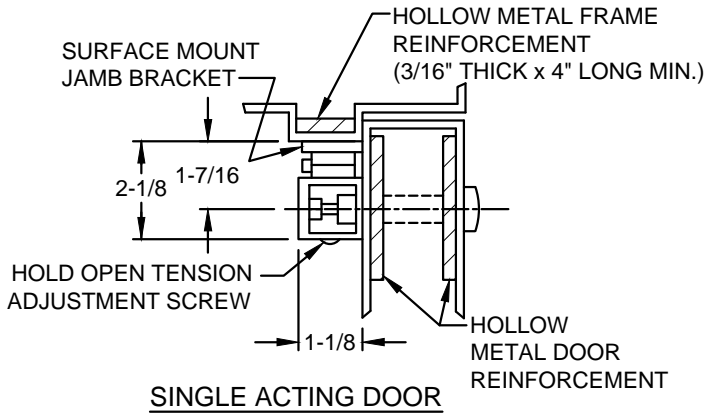

- NOTES:**
1. FOR SINGLE ACTING DOORS ONLY.
  2. REVERSIBLE/ NON-HANDED
  3. ALL DRILLING AND TAPPING TO BE DONE IN FIELD.
  4. ALWAYS REQUEST LATEST TEMPLATE/ DRAWINGS FOR NEW INSTALLATIONS
  5. ALL DIMENSIONS ARE IN INCHES.
  6. DRAWING IS NOT TO SCALE.

DOOR THICKNESS 1-3/4" TO 2-1/4"	MODEL NO.	DOOR FRAME OPENING	SET FOR 95° H.O.		
			A	B	C
STANDARD BUTT HINGES & 3/4" OFFSET PIVOTS	● 9011A HOLDER ● 9021A STOP ● 9031A FRICTION	28" TO 31-15/16"	2-1/4	6-3/4	20-15/16
	● 9012A HOLDER ● 9022A STOP ● 9032A FRICTION	32" TO 39-15/16"	5	7-3/4	22-13/16
	● 9013A HOLDER ● 9023A STOP ● 9033A FRICTION	40" TO 43"-15/16"	10-5/8	9-5/8	25-5/8
	● 9014A HOLDER ● 9024A STOP ● 9034A FRICTION	44" TO 54"	13-5/8	10-1/2	26-7/8



www.abhmfg.com  
 E-mail: abhinfo@abhmfg.com  
 Architectural Builders Hardware Mfg., Inc.  
 1222 Ardmore Ave., Itasca, IL 60143  
 630.875.9900; FAX 800.9FAXABH (932.9224)

©2017 ABH Mfg., Inc.  
 printed in USA

9000A-01.DWG

9000A

PAGE 1 OF 1  
 REVISED 10-19-17