

6200 SERIES INSTALLATION, "B" ASYLUM TRIM ROUND KNOB -OR- "C" ASYLUM TRIM ANGLE KNOB



NOTES

1. TRIM CAN BE MOUNTED UP, DOWN, HORIZONTALLY OR VERTICALLY. **
2. USES STANDARD 161 DOOR PREP.
3. VISION LITE MUST BE AT LEAST 6" FROM LATCH PREP.

| ITEM | QTY | PART DESCRIPTION |
|------|-----|------------------------------------|
| 1 | 1 | COVER |
| 2 | 4 | 8-32 x 3/8" FHMS |
| 3 | 4 | 10-32 x 1-1/2" PH. PAN HD. M.S. |
| 4 | 1 | HANDLE TRIM ASSEMBLY, PUSH OR PULL |
| 5 | 2 | #8 x 3/4" PH. FL. HD. W.S. |
| 6 | 1 | LATCH |
| 7 | 1 | "B" OR "C" ASYLUM TRIM ASSEMBLY |
| 8 | . | . |
| 9 | REF | SPRING |
| 10 | REF | PIN & COTTER PIN |

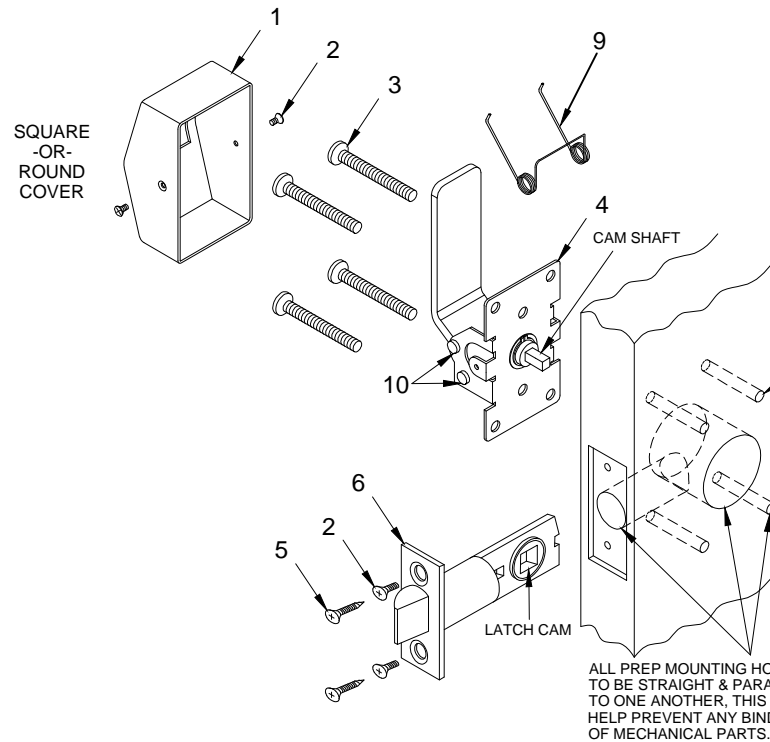

VERIFY CORRECT BACKSET AND HORIZONTAL OR VERTICAL MOUNTING BEFORE DRILLING. THEN USE BACKSET TEMPLATE THAT IS SUPPLIED.

▲ = (4) THRU HOLES MUST BE 3/8" DIA.

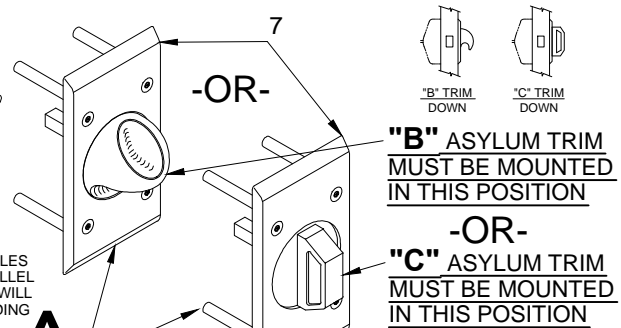

"B" ASYLUM TRIM MUST BE MOUNTED IN THIS POSITION

**-OR-
"C" ASYLUM TRIM MUST BE MOUNTED IN THIS POSITION**

ASYLUM TRIM ASSEMBLY IS PRE ASSEMBLED AT THE FACTORY

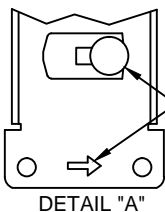

NOTE: BEFORE MOUNTING BASE ASSEMBLIES CAM PIN MUST BE ROTATED TOWARDS SIDE INDICATED BY ARROW STAMPED ON THE BASE.

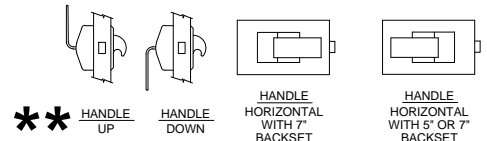

INSTALLATION INSTRUCTIONS:

1. Prep door according to latch backset and determine if trim is to be mounted horizontal or vertical mounting using backset template. ▲
2. Install latch using either wood (item 5) or machine screws (item 2) depending on door type.
3. Assemble trim:
 - A) Select the handle first. With handle in hand, rotate the cam assembly until the cam pin stops on the appropriate side indicated by the arrow (see Detail "A").
 - B) Place handle on appropriate side of the door and slide cam shaft through the latch cam. Then place the asylum trim on the other side of the door engaging the asylum cam onto the handle cam shaft. Mount trim with (4) 10-32 machine screws (item 3). Test both trim handles for free movement of the latch bolt before tightening all screws. If latch bolt does not extend or retract freely because of any type of binding. Loosen mounting screws to adjust alignment of trim and re-tighten screws one at a time while checking latch bolt movement from both sides of the door.
 - C) Test for proper operation and check that the mounting hardware (item 3) & (item 7) **IS TIGHT** before proceeding with the next step.
 - D) Place cover (item 1) over handle trim assembly and secure with (2) 8-32 screws (item 2).

PATENT No. 6,196,599



® www.abhmfg.com
E-mail: abhinfo@abhmfg.com
Architectural Builders Hardware Mfg., Inc.
1222 Ardmore Ave., Itasca, IL 60143
630.875.9900; FAX 800.9FAXABH (932.9224)

© 2017 ABH Mfg., Inc.
printed in USA

6200-1-00.DWG
6200
"B" OR "C" TRIM OPTION
PAGE 1 OF 3
ISSUED 07-06-17

6200 SERIES, ASYLUM TRIM - DOOR PREP

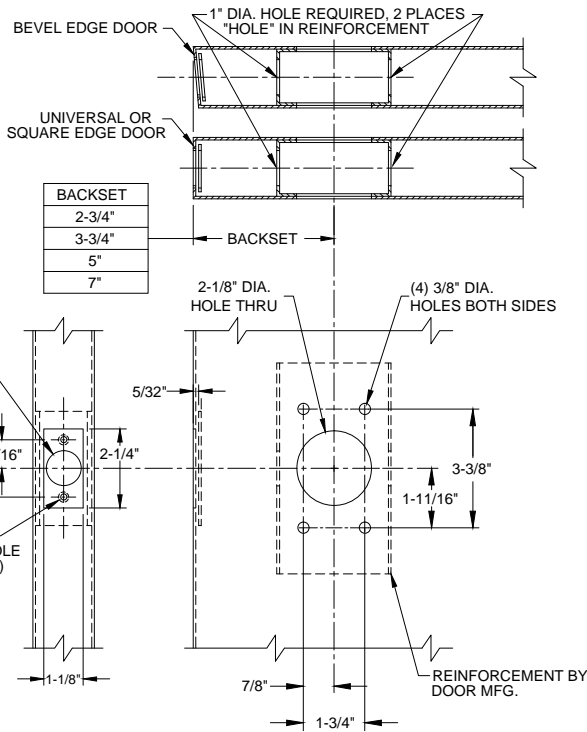

METAL DOOR
(VERTICAL MOUNTING SHOWN)

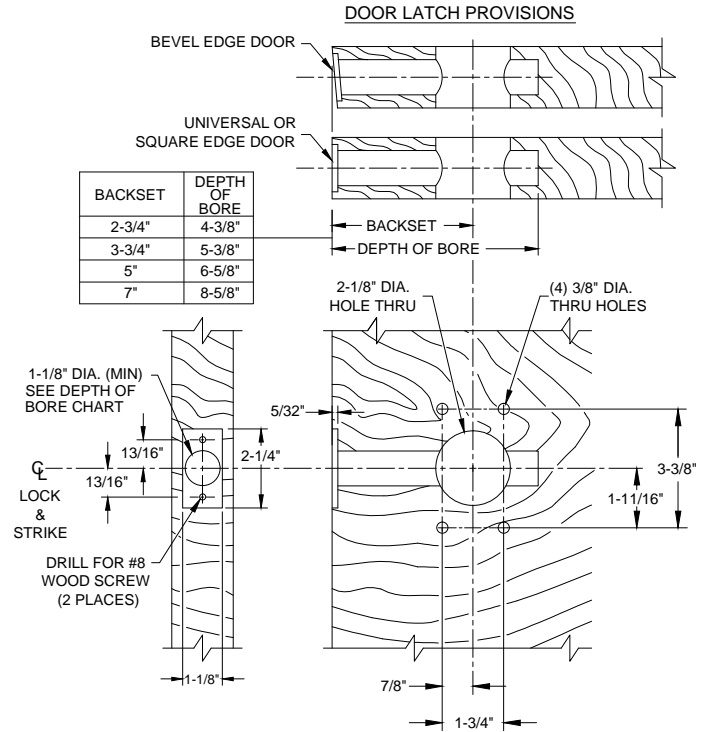

WOOD DOOR
(VERTICAL MOUNTING SHOWN)

DOOR PREP INFORMATION:

1. BACKSET DIMENSION FROM LOW EDGE OF BEVEL.
2. CENTER PUNCH ALL HOLES.
3. DRILL HOLES (FOR HOLLOW METAL DOORS, DO NOT DRILL THRU. CENTER PUNCH & DRILL HOLES FROM BOTH SIDES OF DOOR).

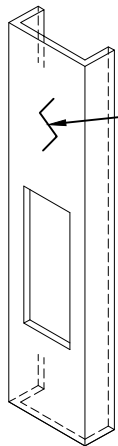

EDGE GUARD NOTE:
WHEN PREPPING THE DOOR FOR THE BACKSET, DETERMINE IF THE DOOR WILL RECEIVE AN EDGE GUARD. IF SO, THE EDGE GUARD SHOULD BE INSTALLED FIRST AND THEN THE PREP FOR THE LATCH BACKSET SHOULD BE MEASURED FROM THE OUTSIDE EDGE OF THE EDGE GUARD.

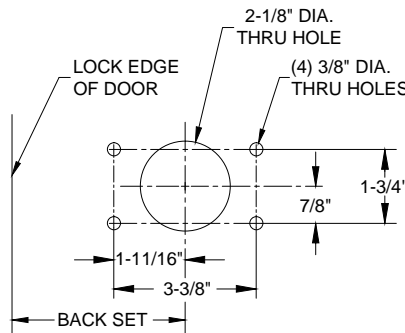

HORIZONTAL MOUNTING

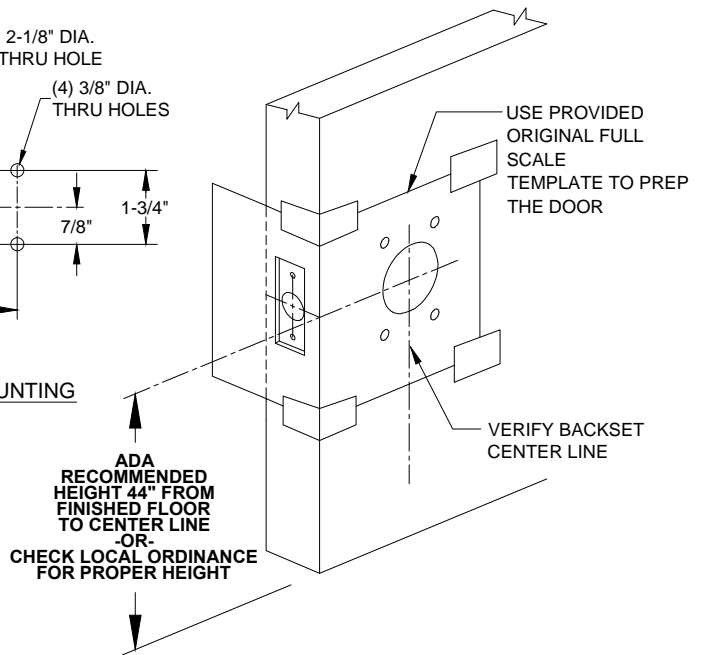

® www.abhmfg.com
E-mail: abhinfo@abhmfg.com
Architectural Builders Hardware Mfg., Inc.
1222 Ardmore Ave., Itasca, IL 60143
630.875.9900; FAX 800.9FAXABH (932.9224)

© 2017 ABH Mfg., Inc.
printed in USA

6200-00.DWG
6200
"B" OR "C" TRIM OPTION
PAGE 2 OF 3
ISSUED 07-06-17

6200 SERIES, ASYLUM TRIM - FRAME PREP

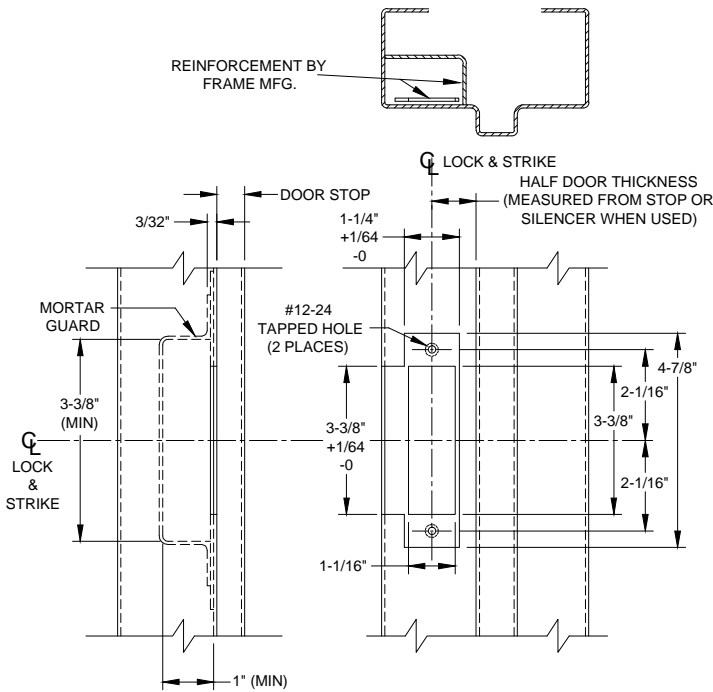

METAL FRAME
(ASA STRIKE SHOWN FOR EXAMPLE)

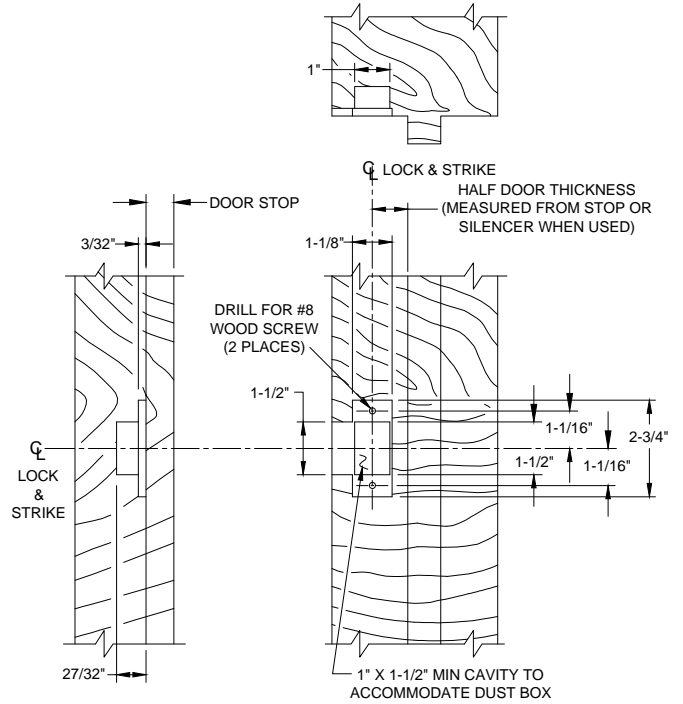

WOOD FRAME
("T" STRIKE SHOWN FOR EXAMPLE)

FRAME PREP:

1. Mark centerline of latch bolt on frame.
2. Center strike and mark screw positions.
3. Mortise to required strike and box depth.
4. All dimensions in inches.

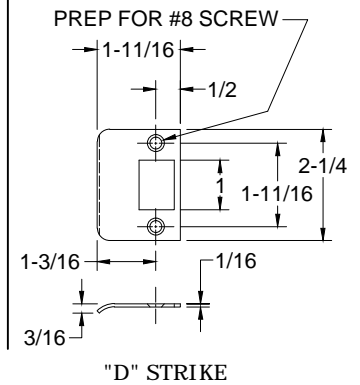
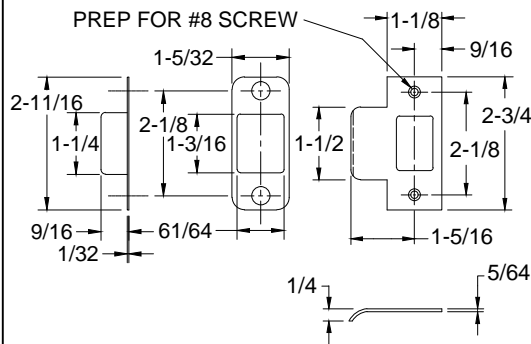
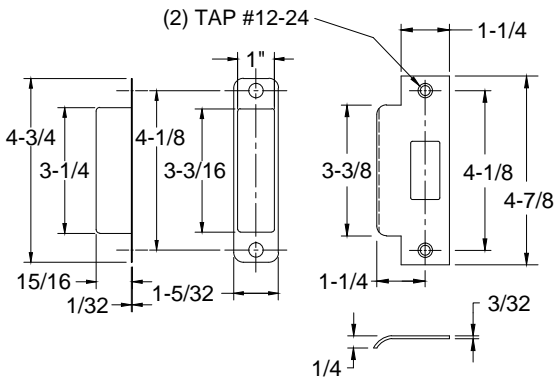
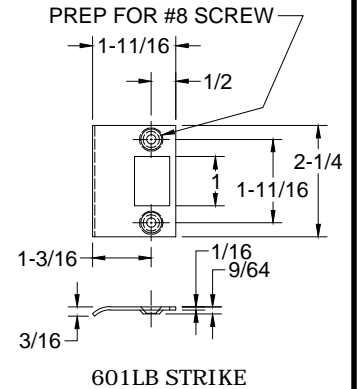
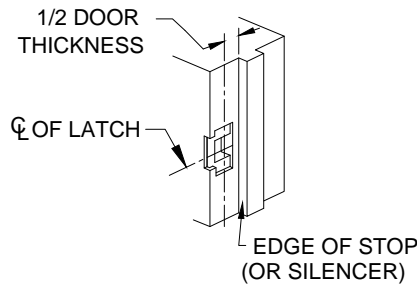

® www.abhmfg.com
 E-mail: abhinfo@abhmfg.com
 Architectural Builders Hardware Mfg., Inc.
 1222 Ardmore Ave., Itasca, IL 60143
 630.875.9900; FAX 800.9FAXABH (932.9224)

©2017 ABH Mfg., Inc.
 printed in USA

6200-3-00.DWG
6200
"B" OR "C" TRIM OPTION
 PAGE 3 OF 3
 ISSUED 07-06-17