

**Medium duty overhead holder and stop
for interior doors,
single or double acting**

**Now available
US32D & US32**

**4000 SERIES
CONCEALED**



STANDARD FEATURES

- For All Stainless Steel Components - Prefix N
- Field adaptable functions
- Non-handed/reversible
- Single point hold-open in increments of 5° from 85° to 110°
- Automatic hold-open and release by push and pull on door
- Friction holder can be adjusted easily on site at any position and held under adjustable pressure
- Maximum opening 110°, minimum door thickness 1 3/8"
- Wood and machine screws included
- Available in all BHMA plated and sprayed finishes

**All Stops
Warnock Hersey
listed**

**WHEN ORDERING,
please list:**

Model number

*Door closer number or other
hardware*

*Mounting means of the door
and butt size*

*Hold-open or dead-stop
degree*

Door opening and thickness

Finish

SPECIFICATIONS:

**Stop only function to be
Warnock Hersey listed as
manufactured by ABH.**

*Material:
Channel-steel/stainless steel
3/4" deep, 3/4" wide and .050
thick; arm-stainless
steel/steel/brass 3/4" wide
and 3/16" thick; jamb bracket
3/4" wide, 3/16" thick and 2
7/8" long; hold-open
mechanism with sliding block
will engage or release door by
push or pull. **Hold-open
mechanism can be
disengaged to function as
stop only.***

DOOR FRAME OPENING		HOLDER NUMBER		
BUTTS OFFSET PIVOTS	CENTER HUNG	HOLD- OPEN	STOP	FRICTION
18" - 23 15/16"	-	4011	4021	4031
24" - 29 15/16"	-	4012	4022	4032
30" - 35 15/16"	32" - 37 15/16"	4013	4023	4033
36" - 48"	38" - 48"	4014	4024	4034
BHMA NUMBER		C04511	C04541	C04531
FED. SPEC TYPE		1166	1166A	1164

Contact ABH for special templating or other door opening
Average weight/unit 1 3/4 lbs.

www.abhmfg.com
E-mail: abhinfo@abhmfg.com
Architectural Builders Hardware Mfg., Inc.
1222 Ardmore Ave., Itasca, IL 60143
630.875.9900; FAX 800.9FAXABH (932.9224)

© 2005 ABH Mfg., Inc.
Printed in USA 02/05



REVERSIBLE

4000 SERIES CONCEALED HOLDERS & STOPS

NON - HANDED

FOR SINGLE OR DOUBLE ACTING DOORS
 18" TO 29 15/16" DOOR OPENING
 BUTT, INVISIBLE, HOSPITAL, OFFSET PIVOTS

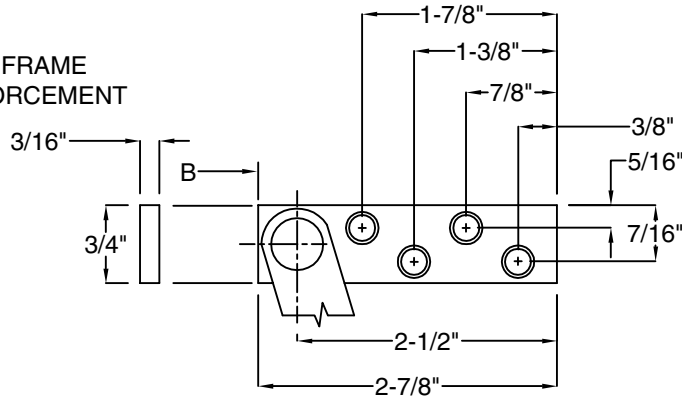
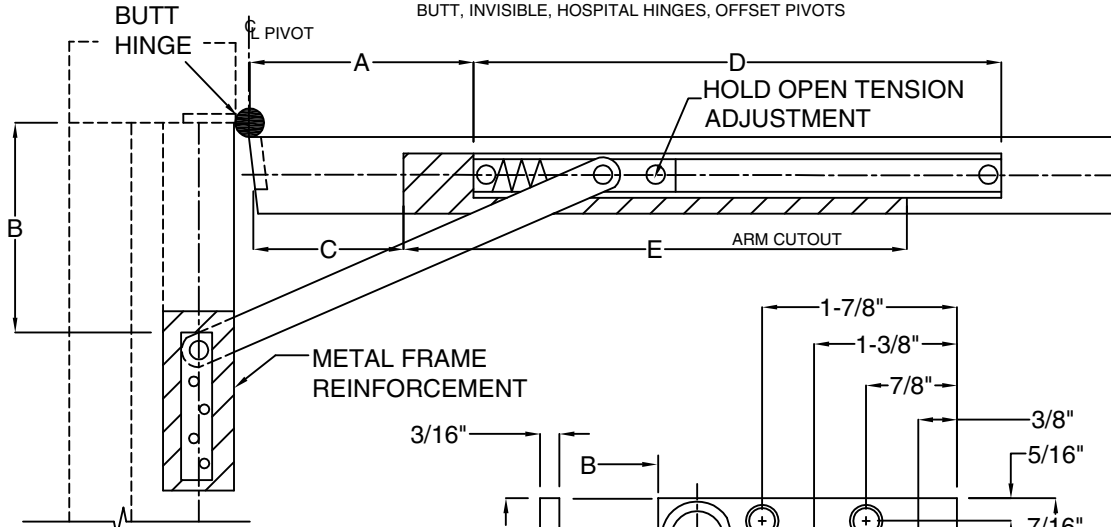

JAMB BRACKET

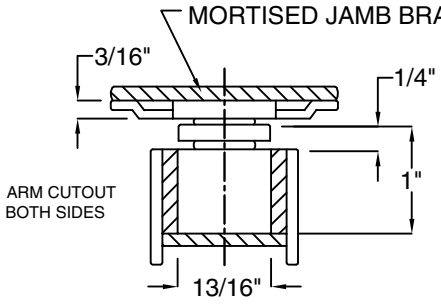

DOUBLE ACTING DOOR

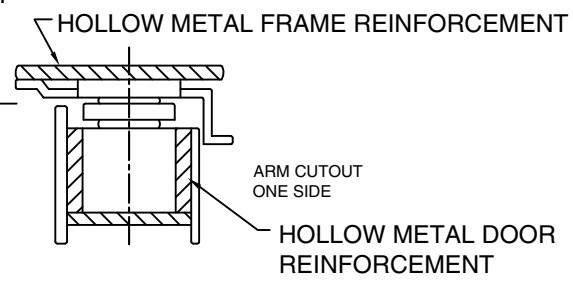

SINGLE ACTING DOOR

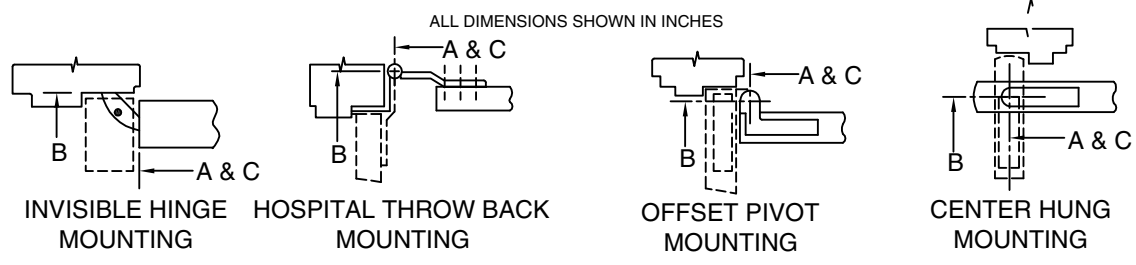

NOTE: A, B, & C DIMENSIONS MEASURED AS SHOWN

SCREW DETAIL			
	QTY	WOOD	METAL
JAMB	4	No.10 x 1-1/2" F.H.W.S	10-32 x 1/2" F.H.M.S
DOOR	2	No.10 x 1-1/2" R.D.H.W.S	10-32 x 1-1/4" R.D.H.M.S

ALWAYS REQUEST LATEST TEMPLATE DRAWINGS FOR NEW INSTALLATIONS

DO NOT SCALE DRAWINGS
 ALL DIMENSIONS ARE IN INCHES

www.abhmfg.com
E-mail: abhinfo@abhmfg.com
Architectural Builders Hardware Mfg., Inc.
 1222 Ardmore Ave., Itasca, IL 60143
630.875.9900; FAX 800.9FAXABH (932.9224)

© 2005 ABH Mfg., Inc.
 Printed in USA 02/05

