

# DOOR CLEARANCES FOR HALF SURFACE GEAR HINGES

A460 SHOWN FOR EXAMPLE  
PAIR DOORS SQUARE EDGE

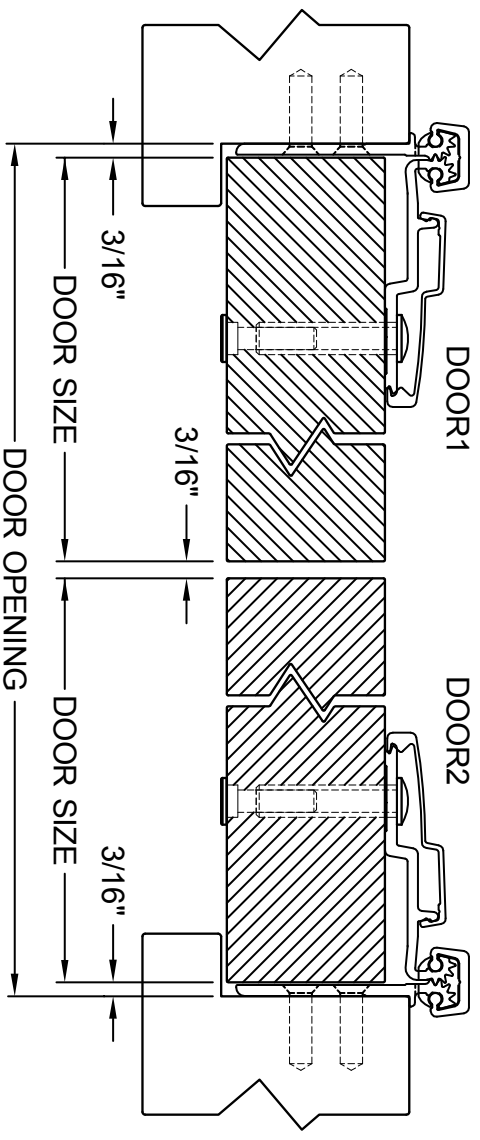

<b>DOUBLE DOOR CLEARANCE</b>	
HINGE SIDE CLEARANCE(2X)	3/16"
LATCH SIDE CLEARANCE	3/16"
TOTAL WIDTH CLEARANCE	9/16"

A460 SHOWN FOR EXAMPLE  
SINGLE DOOR SQUARE EDGE

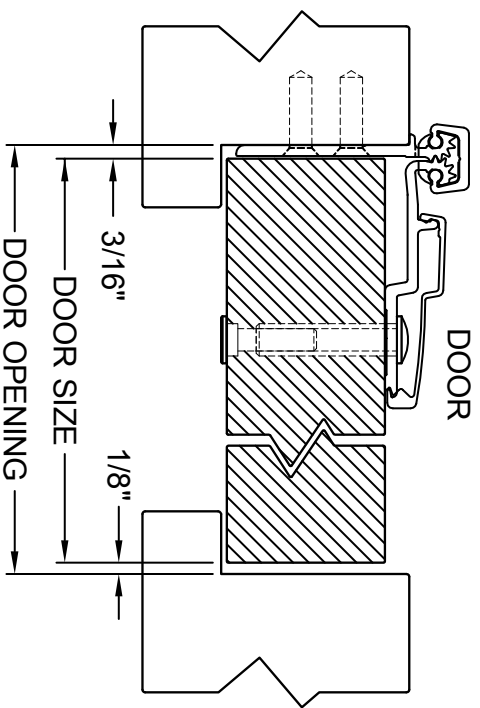

<b>SINGLE DOOR CLEARANCE</b>	
HINGE SIDE CLEARANCE	3/16"
LATCH SIDE CLEARANCE	1/8"
TOTAL WIDTH CLEARANCE	5/16"

NOTE:  
FOR DOUBLE DOOR ENTRANCES WITH A MULLION **BETWEEN** THE PAIR OF DOORS,  
CALCULATE EACH DOOR WIDTH USING THE SINGLE DOOR CLEARANCES.  
FOR DOUBLE DOOR ENTRANCES WITH A MULLION **BEHIND** THE PAIR OF DOORS,  
CALCULATE EACH DOOR WIDTH USING THE DOUBLE DOOR CLEARANCES.

**TO DETERMINE DOOR WIDTH**  
**SUBTRACT THE TOTAL WIDTH**  
**CLEARANCE FROM THE WIDTH**  
**OF THE FRAME OPENING.**

[www.abhmf.com](http://www.abhmf.com)

E-mail: [abhinfo@abhmf.com](mailto:abhinfo@abhmf.com)  
Architectural Builders Hardware Mfg., Inc.  
1222 Ardmore Ave., Itasca, IL 60143  
630.875.9900; FAX 800.9FAXABH (932.9224)

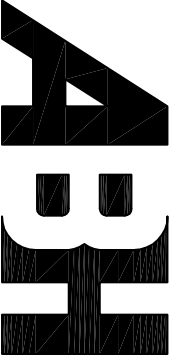

A211, A213, A450, A460, A530, A540, A550

© 2009 ABH Mfg., Inc.  
printed in USA

ISSUED 06-04-09