

A530 SERIES

HALF SURFACE, NARROW FRAME LEAF, 3/32" INSET

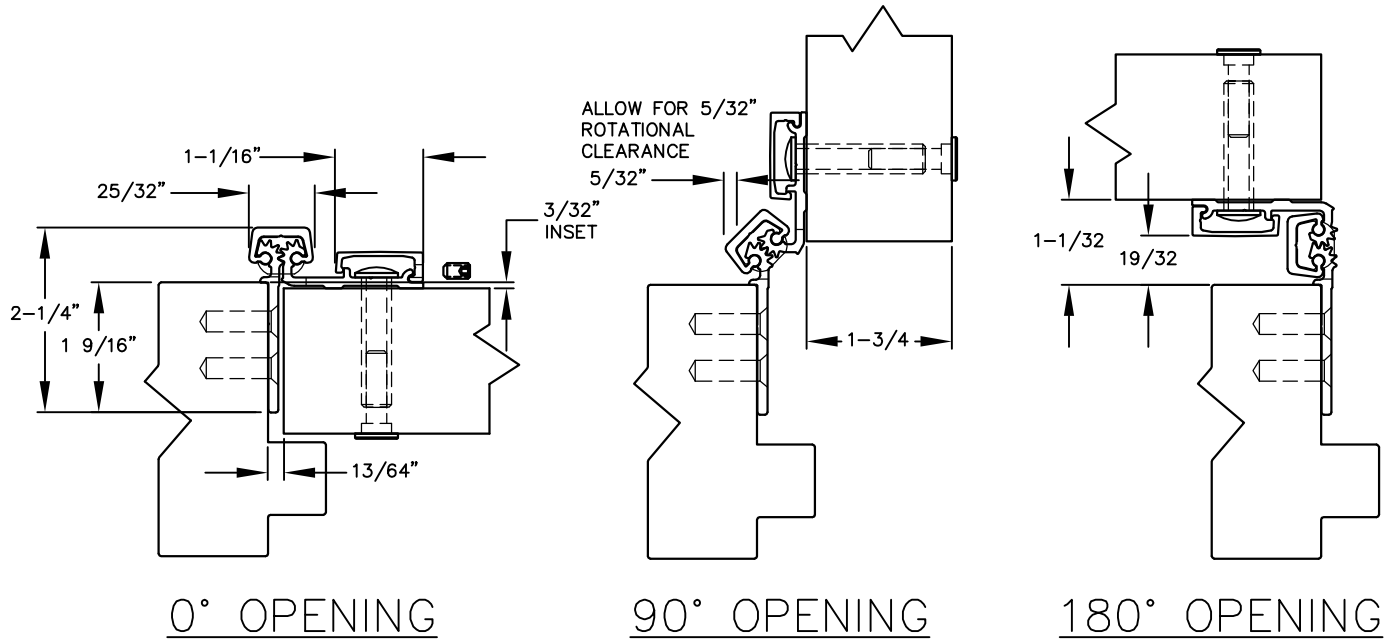

- >> MATERIAL: EXTRUDED 6063-T6 ALUMINUM ALLOY WITH POLYACETAL THRUST BEARINGS
- >> COLOR: 30 MINUTE CLEAR ANODIZED AND 2-STEP DARK BRONZE ANODIZED
- >> CUSTOM HOLE LOCATIONS: HOLE SIZES & LOCATIONS PER CUSTOMER SPECIFICATIONS.
- >> DOOR TYPE: FOR 1-3/4" DOORS STANDARD, HEAVY DUTY UP TO 450 LBS.
- >> DOOR REINFORCEMENT: NONE REQUIRED.
- >> FRAME REINFORCEMENT: OVER 200 LBS. REINFORCE WITH 16 GA. CHANNEL.
- >> SPECIAL FEATURES: FOR USE WITH FLUSH ALUMINUM, GLASS RAIL HOLLOW METAL OR WOOD DOORS.
- >> HINGE KING: TEMPLATED AND HOLE PATTERN IS THE SAME FROM HINGE TO HINGE.
- >> HANDING: HINGE IS NON-HANDED UNLESS CUT IN THE FIELD.
- >> FIRE RATING: UL LISTED FOR UP TO 3 HOUR RATED DOORS WITH USE OF A STEEL STUD.
- >> SCREW DETAIL: 12-24 X 7/8" PH. F.H. UNDERCUT SELF DRILLING THREAD FORMING TEK SCREW & 1/4-20 X 1-9/16L. X 3/8 DIA. SEX-BOLT WITH 1/4-20 X 1" PH. HEAD SHOULDER SCREWS, FOR THE DOOR.

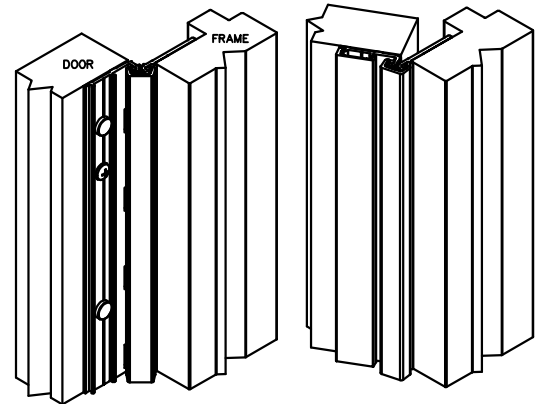

ABH MODEL NUMBER	LENGTH		SCREW COUNT	
	INCHES	CENTIMETERS	# FOR DOOR	# FOR JAMB
A530HD83 (STD/HD)	83	210.8	14	19
A530HD85 (STD/HD)	85	215.9	14	19
A530HD95 (STD/HD)	95	241.3	15	21
A530HD120 (STD/HD)	120	304.8	18	23



® www.abhmfg.com

E-mail: abhinfo@abhmfg.com

Architectural Builders Hardware Mfg., Inc.

1222 Ardmore Ave., Itasca, IL 60143

630.875.9900; FAX 800.9FAXABH (932.9224)

A530-02.DWG

© 2010 ABH Mfg., Inc.
printed in USA

A530

REVISED 10-28-10