

7000 SERIES HEAVY DUTY HOLDERS & STOPS

REVERSIBLE

NON - HANDED

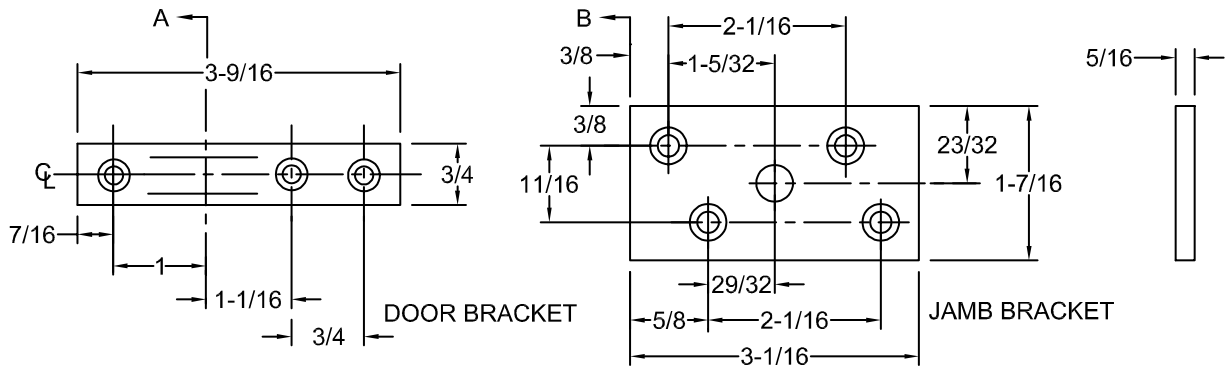
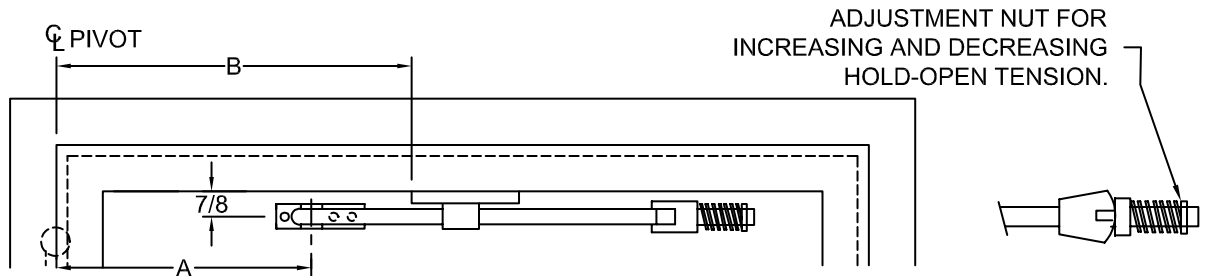
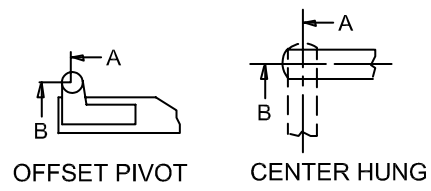
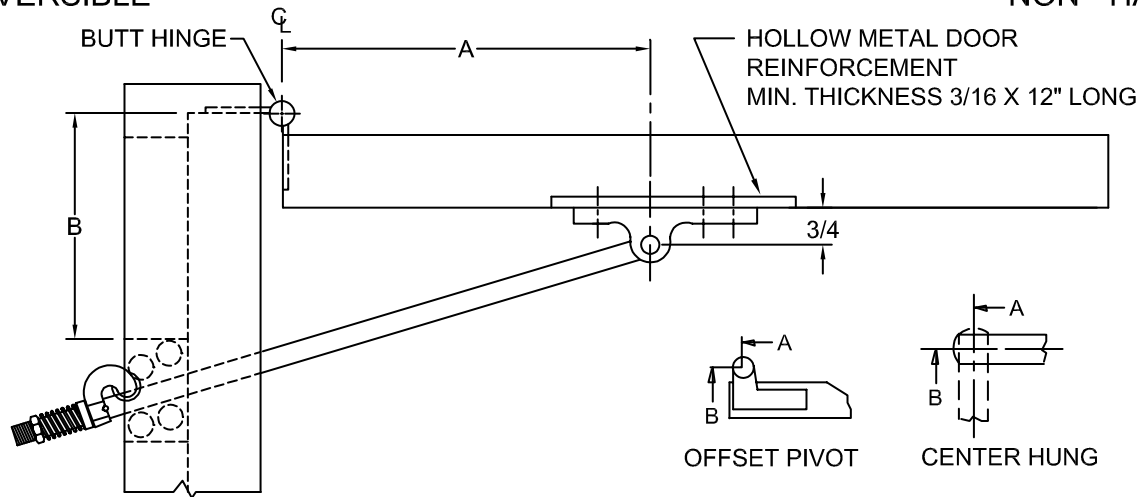

NOTE: ALL A & B DIMENSIONS MEASURED FROM ϕ OF PIVOT.

SCREW DETAIL			
	QTY	WOOD	METAL
JAMB	4	No. 14 X 1- $\frac{1}{2}$ " F.H.W.S.	$\frac{1}{4}$ " - 20 x $\frac{3}{4}$ " F.H.M.S.
DOOR	3	$\frac{1}{4}$ " - 20 THRU BOLT W/ GROMMET NUT, LENGTH TO SUIT DOOR THICKNESS	$\frac{1}{4}$ " - 20 THRU BOLT W/ GROMMET NUT, LENGTH TO SUIT DOOR THICKNESS

ALWAYS REQUEST LATEST TEMPLATE DRAWINGS FOR NEW INSTALLATIONS

DO NOT SCALE DRAWINGS ALL DIMENSIONS ARE IN INCHES

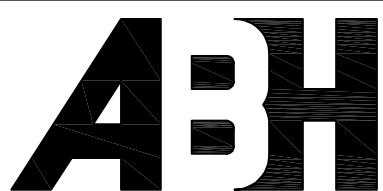

www.abhmfg.com
 E-mail: abhinfo@abhmfg.com
 Architectural Builders Hardware Mfg., Inc.
 1222 Ardmore Ave., Itasca, IL 60143
 630.875.9900; FAX 800.9FAXABH (932.9224)

© 2008 ABH Mfg., Inc.
 printed in USA

7000

REVISED 05-30-08

7010 SERIES HOLDERS & 7020 STOPS SURFACE MOUNTED

REVERSIBLE/ NON-HANDED
ALL DRILLING AND TAPPING TO BE DONE IN FIELD
ALL DIMENSIONS SHOWN IN INCHES

FOR SINGLE ACTING DOORS ONLY
FOR DEAD STOP ADD 3/8" TO "A" DIMENSION

1-1/4" TO 2-3/8" DOOR THICKNESS BUTT & OFFSET PIVOT		85° H.O.		90° H.O.		95° H.O.		100° H.O.		105° H.O.		110° H.O.	
MODEL NO.	DOOR OPENING	A	B	A	B	A	B	A	B	A	B	A	B
7010	23" TO 28-15/16"	5-3/8	8-1/4	5	7-7/8	4-11/16	7-9/16	4-3/8	7-1/4	4-1/8	7	3-7/8	6-3/4
7011	29" TO 34-15/16"	7-15/16	11-7/8	8-3/8	10-1/4	7-15/16	9-13/16	7-1/2	9-3/8	7-3/16	9-1/16	6-7/8	8-3/4
7012	35" TO 40-15/16"	10-9/16	14-1/8	10-15/16	12-5/16	10-7/16	11-13/16	9-15/16	11-5/16	9-1/2	10-7/8	9-1/8	10-1/2
7013	41" TO 46-15/16"	13-1/4	16-7/16	13-9/16	14-1/2	12-15/16	13-7/8	12-3/8	12-5/16	11-7/8	12-13/16	11-7/16	12-3/8
7014	47" - UP	15-1/2	19-13/16	15-7/8	17-11/16	15-3/16	17	14-1/2	16-5/16	13-15/16	15-3/4	13-3/8	15-3/16

"A" & "B" DIMENSION MEASURED FROM CENTER OF PIVOT - NOT EDGE OF DOOR

1-1/4" TO 2-3/8" DOOR THICKNESS CENTER HUNG		85° H.O.		90° H.O.		95° H.O.		100° H.O.		105° H.O.		110° H.O.	
MODEL NO.	DOOR OPENING	A	B	A	B	A	B	A	B	A	B	A	B
7010	24" TO 31-15/16"	5-3/8	8-1/4	5-1/16	7-15/16	4-3/4	7-5/8	4-1/2	7-3/8	4-5/16	7-3/16	4-1/16	6-15/16
7011	32-1/2" TO 38-7/16"	9	10-7/8	8-1/2	10-3/8	8-1/8	10	7-3/4	9-5/8	7-7/16	9-5/16	7-1/8	9
7012	38-1/2" TO 44-3/16"	11-11/16	13-1/16	11-1/8	12-1/2	10-5/8	12	10-1/8	11-1/2	9-3/4	11-1/8	9-7/16	10-13/16
7013	44-1/4" TO 50-3/16"	14-3/8	15-5/16	13-11/16	14-5/8	13-1/16	14	12-9/16	13-1/2	12-1/16	13	11-5/8	12-9/16
7014	50-1/4" & UP	16-3/4	18-9/16	15-15/16	17-3/4	15-3/16	17	14-9/16	16-3/8	14-1/16	15-7/8	13-9/16	15-3/8

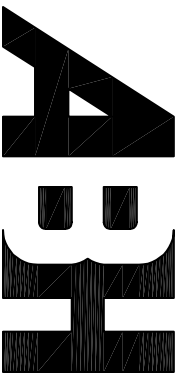

www.abhmfy.com

E-mail: abhinfo@abhmfy.com

Architectural Builders Hardware Mfg., Inc.

1222 Ardmore Ave., Itasca, IL 60143

630.875.9900; FAX 800.9FAXABH (932.9224)

©2008 ABH Mfg., Inc.
printed in USA

7000

7000-2-03.DWG

REVISED 05-30-08